



## IFMAR ELECTRIC OFF ROAD RACING AND TECHNICAL RULES

Version: NOV 13 2019

## INDEX

<b>1</b>	<b>RACE FORMAT .....</b>	<b>2</b>
1.1	RACE PACKAGE .....	2
1.2	IDENTIFICATION NUMBERS.....	2
1.3	BADGES .....	2
1.4	OFFICIAL ANNOUNCEMENTS .....	2
1.5	RACING FORMAT .....	2
1.5.B	ENDORSED TIMETABLE .....	3
1.6	HEATS .....	4
1.7	QUALIFYING SYSTEM.....	5
1.8	FINALS.....	6
1.9	RACE DURATION .....	6
1.10	STARTS .....	6
1.11	MARSHALLING .....	7
1.12	FINAL RESULTS .....	7
1.13	TRANSMITTER IMPOUND.....	7
1.15	LAP COUNTING AND TIMING .....	8
<b>2.</b>	<b>PROTESTS.....</b>	<b>8</b>
2.17	DISPLAY OF RESULTS .....	8
2.18	CAR NUMBERS AND LAP COUNTING TRANSMITTERS.. ...	9
2.19	FREQUENCIES .....	9
2.20	PENALTIES AND SANCTIONS.....	9
2.21	PIT ALLOCATION.....	9
2.22	OPENING CEREMONY .....	9
<b>3</b>	<b>OFFICIALS .....</b>	<b>10</b>
3.1	RACE DIRECTOR .....	10
3.2	TIME KEEPING SUPERVISOR .....	10
3.3	REFEREES .....	10
3.4	REFEREES' DUTIES.....	10
3.6	INTERNATIONAL JURY .....	10
3.7	RESPONSIBILITY OF THE INTERNATIONAL JURY .....	10
3.8	INTERNATIONAL TEAM MANAGERS MEETING .....	11
<b>4</b>	<b>TECHNICAL RULES .....</b>	<b>11</b>
4.1	TECHNICAL INSPECTION.....	11
4.2	GENERAL SPECIFICATIONS .....	11
4.3	TWO WHEEL DRIVE CLASS .....	14
4.4	FOUR WHEEL DRIVE CLASS .....	14
4.5	DRIVER AIDS .....	14
<b>5</b>	<b>TRACK STANDARDS.....</b>	<b>14</b>
5.1	SURFACE .....	14
5.2	LAYOUT .....	15
5.3	MAINTENANCE PROCEDURES.....	15
5.4	CONCLUSION .....	15

**To be used in conjunction with :**

- IFMAR general rules
- IFMAR Electric racing Batteries and motors
- IFMAR internal rules
- IFMAR Tournament contracts

# IFMAR ELECTRIC OFF ROAD RACING AND TECHNICAL RULES

## • RACE FORMAT

### 1.1 RACE PACKAGE

- 1.1.1 Upon arrival and registration each driver will be given a race package which contains:
1. A set of numbers for his radio controlled car PLUS three additional sets.
  2. Two sets of participant identification numbers for wing or spoiler.
  3. One identification badge for driver and one for mechanic.
  4. A complete time schedule for all practice, heats and finals for the whole event.
  5. 2 & 4WD may be registered on the first day if participants attend both classes Tyres could be handled on registration day for 4WD and during free practice for 2WD, Drivers only attending 4WD must be allowed to register on the day off. (So that drivers attending both classes and wishing to do so can have a free day when their obligations are fulfilled)
  6. Registration must be closed before the start of the controlled practices (this to ensure to have all participants on the premises and ready to marshal when due).

### 1.2 IDENTIFICATION NUMBERS

- 1.2.1 Each competitor will display on his wing or spoiler his unique identification number. This number will remain the same through the entire event.(Is not the race car number)
- 1.2.2 This ID must be displayed on the right side of the wing or spoiler.

### 1.3 BADGES

- 1.3.1 Two badges will be given to each competitor, one blue for driver and one yellow for mechanic.
- 1.3.2 Access to the pits and track will be restricted and badges must be worn at all times. Badges will be issued as follows:-

Blue	Drivers	Drivers stand, pits, staging area, track.
Yellow	Mechanics	Pits, staging area, track.
Green	Press	Pits, staging area, viewing area.
White	Team Manager	Pits, staging area, viewing area.
Red	Race Official	All areas.
Grey	IFMAR Official	All areas

### 1.4 OFFICIAL ANNOUNCEMENTS

- 1.4.1 All official announcements must be made in English.
- 1.4.2 Referees must be provided with a monitor to show race progress and a microphone linked direct to a speaker mounted on the driver's stand. This is to enable drivers to hear any warnings issued.

### 1.5 RACING FORMAT

- 1.5.1 The track will be closed for a minimum of two (2) and a maximum of thirty (30) days prior to the day one (1) schedule as follows. This closure is to allow the Organizer to put into effect rule 1.5.4 regarding a minimum of 60% change of layout.

Before closure, the track should be available for competitors to practice on. The Organizer's usual conditions shall apply. He must state the availability of practice for all competitors as scheduled by the organization.

Wherever possible it is preferred that the track should be significantly different for 2 and 4WD. Reverse operation is acceptable. If the track contains permanent features or jumps that cannot be changed with reasonable effort, then it is permissible to use the track as is subject to agreement by the section chairman. Maximum track length is 250 meter.

## Endorsed time schedule, 2WD &amp; 4WD

2WD or 4WD - DAY 1

HEAT	MARSHAL	FREE PRACTICE ROUNDS				CONTROL PRACTICE	
		FP 1	FP 2	FP 3	FP 4	CP 1	CP 2
1	15	<b>NOTES Day 1:</b> There must be a minimum of 6 Practice Rounds (total) on Day 1. The last 2 Practice Rounds will be 'Controlled' to obtain lap times for re-seeding prior to Day 2. Each Round starts with Heat 1.(Reseed can be based on best 2 or 3 consecutive laps, 3 may be too many on very large tracks decided in conjunction with Ifmar) If lap times and track length allows, there can be up to 15 drivers in a Practice Heat. This can reduce the number of Practice Heats. Number of Practice Rounds is determined by number of Heats. There must be a minimum of 75 mins. between start of each Round. Turn-round of 6 mins per. Heat for Free Practice can be used even if driving time is a little less than 5 min; CP 1 & 2 need 7 mins turn-round per. Heat. Example is based on 15 Heats.				<b>14:55</b>	<b>16:45</b>
2	1					15:02	16:52
3	2					15:09	16:59
4	3					15:16	17:06
5	4					15:23	17:13
6	5					15:30	17:20
7	6					15:37	17:27
8	7					15:44	17:34
9	8					15:51	17:41
10	9					15:58	17:48
11	10					16:05	17:55
12	11					16:12	18:02
13	12					16:19	18:09
14	13					16:26	18:16
15	14					16:33	18:23
						<b>TRACK CLOSED: 18:30</b>	

2WD or 4WD - DAY 2

**NOTES DAY 2:** Control Practice 3 and all Qualifying Heats need a turn-round of 8 mins. per heat. Stagger of Rounds is as IFMAR Rules, then if there are less than 15 Heats, the Top seeded drivers will still be consecutive which is important if track conditions change during a Round.

HEAT	MARSHAL	CONTROL PRACTICE	QUALIFYING ROUNDS			
		CP 3	Q1	Q2	Q3	Q4
1	15	8:00	10:15	13:56	15:37	17:18
2	1	8:08	10:23	14:04	15:45	17:26
3	2	8:16	10:31	14:12	15:53	17:34
4	3	8:24	10:39	12:20	16:01	17:42
5	4	8:32	10:47	12:28	16:09	17:50
6	5	8:40	10:55	12:36	16:17	17:58
7	6	8:48	11:03	12:44	14:25	18:06
8	7	8:56	11:11	12:52	14:33	18:14
9	8	9:04	11:19	13:00	14:41	18:22
10	9	9:12	11:27	13:08	14:49	16:30
11	10	9:20	11:35	13:16	14:57	16:38
12	11	9:28	11:43	13:24	15:05	16:46
13	12	9:36	11:51	13:32	15:13	16:54
14	13	9:44	11:59	13:40	15:21	17:02
15	14	9:52	12:07	13:48	15:29	17:10

TRACK CLOSED: 18:30

## 2WD or 4WD - DAY 3

### NOTES DAY 3:

Free Practice is a max. of 1 hour -- 15 Heats = 4 mins. turn-round.

Q5 runs from Heat 15 back to Heat 1. Turn-round of 8 mins per Heat.

Finals need 10 mins. turn-round per. Final.

Time between all 'A' Finals (including Practice A) should be equal and min. 1 hour.

HEAT	MARSHAL FP & Q5	FREE PRACTICE	QUALIFYING
			Q 5
1	2	9:26	11:32
2	3	9:22	11:24
3	4	9:18	11:16
4	5	9:14	11:08
5	6	9:10	11:00
6	7	9:06	10:52
7	8	9:02	10:44
8	9	8:58	10:36
9	10	8:54	10:28
10	11	8:50	10:20
11	12	8:46	10:12
12	13	8:42	10:04
13	14	8:38	9:56
14	15	8:34	9:48
15	1	<b>8:30</b>	<b>9:40</b>

*(Q5 or last one to be run backwards from 15 or last heat to 1 ( more time to the top drivers and allows less time to A mains procedures).*

FINALS		
FINAL	MARSHAL FINALS	
<b>A Practice</b>	International	<b>12:30</b>
<b>O</b>	B	<b>12:50</b>
<b>N</b>	O	13:00
<b>M</b>	N	13:10
<b>L</b>	M	13:20
<b>A1</b>	International	<b>13:30</b>
<b>K</b>	L	13:40
<b>J</b>	K	13:50
<b>I</b>	J	14:00
<b>H</b>	I	14:10
<b>G</b>	H	14:20
<b>A2</b>	International	<b>14:30</b>
<b>F</b>	G	14:40
<b>E</b>	F	14:50
<b>D</b>	E	15:00
<b>C</b>	D	15:10
<b>B</b>	C	15:20
<b>A3</b>	International	<b>15:30</b>
<b>TRACK CLOSED: 15:40</b>		

### 16:00 PRIZE CEREMONY

- 1.5.2 There will be a scheduled day off between classes. This day can be used for track repairs.
- 1.5.3 The track layout/design will not be available for running on prior to the first day of practice.
- 1.5.4 If the track is used prior to the commencement date then a minimum of 60% of the layout must be changed prior to the start of practice.
- 1.5.5 Practice will be organized using pre-arranged practice heats. Maximum track time per heat will be six (6) minutes. Practice heats may contain up to a maximum of fifteen (15) drivers. The number of drivers in each Practice Heat will be determined by the size of the track and the lap times, with a maximum of fifteen heats. Practice will be run on standard numerical heat order starting with heat one (1).  
Minimum time between each Practice Round will be 75 minutes.
- 1.5.6 All the IFMAR Technical Rules apply during Controlled Practice, including the use of controlled tyres, batteries and motors from the IFMAR Approved List which have been checked (and marked where necessary) by Technical Inspection. Control Practice 1 & 2 at the end of Day one for each Class are used for re-seeding. Marking of the chassis is not mandatory for CP1 & CP2, but all other controlled items must be used with cars having been through Technical Inspection. Organiser will decide deadline time for chassis marking at the end of day one.

## 1.6 HEATS

- 1.6.1 There will be five (5) rounds of qualifying heats unless weather, daylight or unforeseen circumstances dictate otherwise. Any reduction in the number of rounds will be decided by the International Jury. The sequence of the heats in each round of qualifying will be as follows:  
 Round 1: 1,2,3,4,5,6,7,8,9,10,11,12,13,14,15.  
 Round 2: 4,5,6,7,8,9,10,11,12,13,14,15,1,2,3.  
 Round 3: 7,8,9,10,11,12,13,14,15,1,2,3,4,5,6.  
 Round 4: 10,11,12,13,14,15,1,2,3,4,5,6,7,8,9.  
 Round 5: 15,14,13,12,11,10,9,8,7,6,5,4,3,2,1.

If there are less than fifteen Heats, the start/finish Heats for each round will be adjusted accordingly. (Top seeded Heats should be consecutive to minimize effects of changing track conditions.)

1.6.2 During the first Round of Qualifying, heat starting order will be determined by the times achieved overall **(5 minutes +)** during Controlled Practice 3. During further rounds, heat starting order will be by the overall fastest time of the drivers from ANY previous round.

## 1.7 QUALIFYING SYSTEM

A driver's point score will place the driver in a final according to the following system. In each round, drivers will score points based on the laps and times achieved in relation to all other drivers.

Fastest driver in each round will score: **0** points  
 2nd fastest will score: **2** points  
 3rd fastest will score: **3** points  
 4th fastest will score: **4** points

and so on, scoring one point less for each driver down to last qualifying position.

If a driver does not start a heat, he receives no points (**Attention, no points is NOT zero**). No change to the scoring method will be made if less than 150 drivers enter the World Championship. In each round, in case of a tie, the points will be equally awarded to each driver with the same lap and time score. The first driver not in the tie will score points according to their position in the qualifying list. For example:

Fastest driver	8 laps 5:10.00	will score	0 points
2nd fastest driver	8 laps 5:12.00	will score	2 points
3rd fastest driver	8 laps 5:14.00	will score	3 points
4th fastest driver	8 laps 5:15.00	will score	4 points
5th fastest driver	7 laps 5:01.00	will score	5 points - TIED
6th driver	7 laps 5:01.00	will score	5 points - TIED
7th driver	7 laps 5:01.00	will score	5 points - TIED
8th fastest driver	7 laps 5:04.00	will score	8 points

A driver will discard his worst scores based on the qualifying rounds completed to the following rules:

The normal qualifying will be best three (3) best points rounds out of five (5) rounds. If only four (4) rounds are completed, the two (2) best points rounds will count. If three (3) rounds are completed, the two (2) best points rounds will count. If two (2) rounds are completed, the best single points round will count. If only one (1) is completed, that round will count.

In the case of a tie in the final qualifying positions when the driver's best scores are added together, only the scores (and the laps and times used to determine those scores) will be used to break the tie. The discarded scores, laps and times will not be used to separate a tie. The driver with the lowest single points score from the scores added will be awarded the tied position. In the case of a continuing tie, the next best scores will be considered. All best scores will be considered until the tie is broken.

If a comparison of points fails to break the tie, the laps and times from the lowest points will be compared. The driver with the fastest time from their lowest score will be awarded the tied position. Example, with three (3) from five (5) counting:

Driver	Points Score					Total	Fastest Lap Time
A	5	9	25	10	28	24	8 laps 5:10.00 (Rnd.1)
B	7	8	19	9	22	24	8 laps 5:14.00 (Rnd.1)
C	11	10	24	8	37	29	8 laps 5:12.00 (Rnd.4)
D	10	24	8	11	29	29	8 laps 5:16.00 (Rnd.3)

**Note:** Driver A qualifies ahead of Driver B due to a lower single point score. Driver C qualifies ahead of Driver D due to a better fastest time from their lowest score.

## 1.8 FINALS

1.8.1 The World Championship final will be composed of three separate five minute races composed of the top ten qualifiers after completion of qualifying.

1.8.2 All finals will be of ten drivers.

1.8.3 Final positions will be decided by a point system based on one (1) point for the winner of each final on down to ten (10) points for the tenth placed finisher in each separate final. The best two (2) of three (3) finishes will count. In the event of a tied position, the driver with the single best finishing position in either of the best two (2) finals that counted, will be awarded the tie, in the event of a continuing tie, then the laps and times from the best finishing position will be compared and the one with the fastest laps and time total will be awarded the tie. If still continuing, then times from the second best position will be compared.

### 1.8.4 A-Main Finals

If three (3) finals are completed, the best two (2) will count as per Rule 1.8.3.

If two (2) finals are completed, the best one (1) final will count.

If one (1) final is completed, that one (1) final counts.

If no A-Main Finals are completed, the finishing order of qualifying will be used to determine the final results of the event.

A-Main Finals will have priority and may be moved in an attempt to have them completed if rain is imminent.

Time must be allowed to charge batteries.

## 1.9 RACE DURATION

1.9.1. All heats and finals will be five (5) minutes, plus time to finish last lap. The organisers can restrict the number of 'warm-up' laps prior to any Controlled Practice, Heat or Final to ensure scheduled time is maintained and competitors are not allowed to 'cut' the track to gain an advantage.

## 1.10 STARTS

1.10.1 All starting announcements and warnings will be in English.

1.10.2 A two minute warning will be given before the start.

1.10.3 At the thirty second warning all cars must be placed on the track and the mechanics must leave the racing surface. After the thirty second warning no other cars will be allowed entrance to the racing surface until after the start of the race, at which time the mechanic may place the car on the starting grid after all the cars have left.

1.10.4 A ten second warning will be issued followed by the start which will be by an audible signal.

1.10.5 There will be no restarts due to jump starts.

1.10.6. A video record will be made of all starts for review by the referees as necessary.

1.10.7 There will be a one meter penalty line for jump starts. Any car crossing that line before actual start will receive a one lap penalty. Any car jump starting but not crossing the one meter line will receive a ten second penalty.

1.10.8 During qualifications the "staggered start" system will be used. Each car will start separately within one second of its number being called. Starting before its number is called will be classified as a jump start.

1.10.9 If for any reason a car did not start prior to the completion of the first lap by any car, the time for that car will automatically begin the moment the first car has completed a lap.

1.10.10 All main finals will use a staggered grid start of ten (10) rows with one and a half (1.5) meter minimum spacing without being directly in line with the car in front. Two (2) meter maximum spacing is recommended, if possible.

### EXAMPLE

Spacing 1.5 Meter	0	1,5	3	4,5	6	7,5	9	10,5	12	13,5
2 Meter	0	2	4	6	8	10	12	14	16	18
Car #	1		3		5		7		9	
Car #		2		4		6		8		10

- 1.10.11 Any race stopped due to the organiser's race equipment malfunction or race management error will be re-run after a suitable delay.

## **1.11 MARSHALLING**

- 1.11.1 Marshalling will be done by competitors in the event. The Race Organisers will provide 2 designated fill-in marshals to cover unforeseen eventualities. After each heat the participants in that heat will place their cars into impound and assume assigned marshalling positions for the following heat. No other person is allowed on the track (except officials) while the race is in progress.  
An exception must be possible in case of very young drivers or a physically disabled person after consultation with the Race director.
- 1.11.2 When there is a break, staggering of heats or a change in the running order of heats, any driver that is responsible for marshalling will be properly notified either in person or through his country's Team Manager.
- 1.11.3 Only competitors in the event may marshal or if disabled must provide a qualified marshal agreed by the race director. Except for the back-ups provided by the organizer.
- 1.11.4 Numbered positions for marshals must be spread around the track not obstructing the view of the drivers. If needed these positions must be protected against car impacts.  
Marshals compulsory to wear safety jackets and adequate footwear.
- 1.11.5 The organization of drivers marshalling the finals is the responsibility of the organiser. Only drivers taking part in the competition may and must marshal unless a substitute was granted. Allocation of marshals to the country teams may be based on size of team (i.e: a country with a large number of entrants provides maximum 2 drivers smaller ones 1 and the smallest ones none although they may volunteer to provide one.
- 1.11.6 The organizer is to provide a marshal for any unfilled position ( i.e. if previous run did not have 10 drivers)
- 1.11.7 Team managers, once briefed are responsible to ensure that the numbers requested are provided in due time. Failing to do so will be subject to sanctions for unsporting behaviour and the concerned Bloc/Country will be informed and must take corrective actions and revert to IFMAR or will see it's allotment for any next event considerably reduced.
- 1.11.8 Any failure to marshal will result in loss of best points score from any Rounds at the end of qualifying.  
Repeating to fail or refuse to marshal will result in being excluded from further participation due unsporting behaviour.

## **1.12 FINAL RESULTS**

- 1.12.1 Results of each sub-final will be posted upon completion of the final and review by the officials.
- 1.12.2 Results of the World Championship finals will be posted following completion of each final and review by IFMAR officials.
- 1.12.3 As soon as the IFMAR officials have reviewed the results of the three World Championship finals and verified such results the official finishing positions and points will be announced and the World Champion will be presented on the podium.
- 1.12.4 Awards and complete introduction of competitors and their final placing will be at the Awards' Banquet following the finals.

## **1.13 TRANSMITTER IMPOUND**

- 1.13.1 With the use of 2.4G transmitters, providing there is agreement from all IFMAR Officials, Organisers and Team managers, the transmitter compound can be abandoned and rules. In this case, competitors are not allowed to switch-on transmitters other than when racing or under the authority of Technical Inspection. No cars can be used, driven, tested or tyres 'scrubbed' anywhere, other than on the track during official procedures (oil differentials are allowed to be run-in in the pit-lane area). The transmitter impound can be reinstated at any time if the IFMAR Officials or Organisers deem it necessary.

## **1.15 LAP COUNTING AND TIMING**

- 1.15.1 Automatic lap counting, with cumulative and split lap times, will be in place for each car. Competitors are required to install a small compatible transponder into their cars according to the organizer's instructions. An audio/video tape recording will be made.

Every competitor is allowed to use his own IFMAR approved personal transponder if the lap counting officials are informed and agree. NOTE: If a competitor chooses to use a transponder which is not specified as being suitable by the timing decoder manufacturer, then any missed laps/time is the responsibility of the competitor. The Time Keeper is not required to perform a manual count or adjust times if a non-specified transponder is used, but can do so at his/her discretion.

If an organizer is using a personal transponder system, he may provide to all participants not having their own, a transponder. A deposit of the replacement value for this transponder may be demanded. If a competitor by any reason destroys or does not return the transponder, he loses his deposit.

The driver has to ensure that his personal private transponder belongs to the marked chassis.

Significant stops (tyre changes, crashes, etc.) will be noted with times of stop and restart. This record might not include every incident, however, its intent is to verify incidents, whenever possible. My Laps lap counting system or IFMAR approved equivalent must be used in complete duplicate and 2 separate loops

A suitable working computer with proper race proven programs must be used to sort lap times, print results from heats and sort final positions from each round of heats within minutes of the completion of the round of heats.

Timings must give time to 1/100th of a second, in all cases, the hundreds will be utilized.

In the case of equal times in any Round, the competitors with equal times will be awarded the same points. The next scoring competitor will be awarded points as rule 1.7 (see table).

If both the primary and support lap counting systems fail during a qualifying heat or final, the heat or final will be re-run as soon as is practicable. Under no circumstances will any lap score or time, other than those from the official time keeping equipment, be accepted for any purpose to do with the running of an IFMAR race.

## **2 PROTESTS**

- 2.1 Lap count checking:

This need not be written and does not need a deposit. The Team Manager will, within fifteen (15) minutes of the display of the results, show to the race direction officials the time lap sheet involved (the one displayed by the officials) and will indicate where he thinks an error has been made. This must be shown to the Race Director and the Timekeeper. If the request is justified, correction will be made immediately. The Timekeeper will advise in writing the result of the findings and the time will be noted. After the examination, if the team manager persists, he may then submit a written protest along with a US\$100 protest fee. This will then be processed as a formal protest.

- 2.2 Formal protest:

Must be done within fifteen (15) minutes after the display of the results or the occasion it concerns, in writing and with a US\$100 protest fee. Protest must be in English. The time of the display will be written on the result sheets and protests must be made within fifteen (15) minutes of that time. The protest fee is forfeited if the protest is not upheld, and returned if justified. The protest may be given to the Race Director or to an IFMAR official. Protests are processed by the Race Director and if necessary the IFMAR International Jury. Appeals against the Race Director's decision may be made to IFMAR. IFMAR is obliged to handle such an appeal.

## **2.3 DISPLAY OF RESULTS**

- 2.3.1 At the end of each heat and final, and after official review, the results will be displayed with reasonable despatch for the competitor's checking and information.
- 2.3.2 The result sheet will include lap times and finishing positions. The display sheet will also display



the official time of posting.

## **2.4 CAR NUMBERS AND LAP COUNTING TRANSMITTERS**

- 2.4.1 Only the numbers supplied by the organizer will be used on the car.
- 2.4.2 Each competitor is responsible for attaching the adequate lap counting transponder firmly in an adequate position to his car.
- 2.4.3 Any car starting without, or a wrong transponder will not be counted. If, during a heat or final, the transponder fails or falls off the car, the car may be counted and timed manually if possible. In this case the Race Director will verify the results and his decision will be final.
- 2.4.4 Under no circumstances will a heat or final be re-run due to a car not having a transponder, the wrong one or failure of such. This also applies to a car having an incorrect number.

## **2.5 FREQUENCIES AND COMMUNICATION DEVICES**

- 2.5.1 Fixed frequencies and 2.4GHz DSM/DSS systems: These systems may only be used as permitted in the organizing country. However, due to the way they operate, a driver using such a system cannot ask for any delay in case of radio problems.
- 2.5.2 No radio communication or any other form of communication deemed to be an advantage between the driver and pit crew is allowed during any Heat or Final. There will be no form of 'coaching' to drivers during any Heat or Final .

## **2.6 PENALTIES AND SANCTIONS**

- 2.6.1 Black flag (removal of car from track) may be issued for the following reasons:
  - a. Drivers who impede the progress of other drivers.
  - b. Un-sportsmanlike driving.
  - c. Participants driving in a manner deemed to be dangerous.
  - d. Vehicles judged to be in an un-driveable or dangerous condition by the Race Director. These vehicles, after being repaired, may be allowed to re-enter the track after permission by Race officials.
  - e. Vehicles losing their body must immediately leave the track and carry out necessary repairs before re-entering track.
  - f. Any illegal modifications or changes made to the vehicle which are found during technical inspection at the end of a heat or final will automatically cause disqualification from the respective heat or final.
  - g. Any vehicle which, by the fault of another driver, is damaged or obstructed during a heat or final will not, under any circumstances, be allowed to re-run in another heat.
  - h. All participants must strictly observe the instructions and warnings by the Race Co-ordinator, Race director and Referees.
  - i. The bad behaviour and/or deportment of any competitor, even outside an official race meeting, which could injure the promotion of the sport, may become the object of an official national or international sanction.

## **2.7 PIT ALLOCATION**

- 2.7.1 Pit spaces are allocated by the organiser for the duration of the World Championship and drivers will be allocated spaces in Country Teams.
- 2.7.2 Each competitor will have a minimum of 12.5 Sq Ft of table space with a min. depth of 2ft.

## **2.8 OPENING CEREMONY**

An Opening Ceremony will be held on Day 1 for both classes. Competitors will participate in a welcoming procession. Each national team is asked to wear similar shirts. A sign bearing the name of each country will be provided by the organizer for each team. The use of national Hymns is NOT mandatory. Other suitable up tempo music is allowed.

### **3 OFFICIALS**

#### **3.1 RACE DIRECTOR**

- 3.1.1 The Race Director must be approved by IFMAR and the appropriate host Bloc and is under the direct authority of IFMAR's representative.
- 3.1.2 The Race Director within the schedule of the event is responsible for ensuring that the various tasks under his responsibility are managed and correctly done. These include:
- a. Time keeping / Supervisors
  - b. Race co-ordination officer (Starts: flagman)
  - c. Marshalling management
  - d. Timely Display of results
  - e. Announcements
  - f. Technical inspection
  - g. Frequency control.
- 3.1.3 Receive any protests and call the International Jury, if necessary.
- 3.1.4 Make urgent decisions for safety or unforeseen situations in close co-operation with the risk management officer (RMO).

#### **3.2 TIME KEEPING SUPERVISOR**

- 3.2.1 The Time Keeping Supervisor is responsible for recording all laps, times, and results of all drivers in all heats and finals. He must have sufficient knowledge to operate and intervene with all the set-ups of the used soft- and hardware. He is responsible for classifying the results and setting up the mains. The Race Director must verify this classification and selection
- 3.2.2 After the end of all heats and sub-finals the Time keeping supervisor will review the results before displaying.

#### **3.3 REFEREES: See general rules**

#### **3.6 INTERNATIONAL JURY**

- 3.6.1 The International Jury consists of official representatives from ROAR, EFRA, FEMCA and FAMAR. Each Bloc will have a total of one (1) vote.
- 3.6.2 The relevant IFMAR Section Chairman shall always act as Chairman during International Jury Meetings and exercise a casting vote, if necessary. In the absence of the relevant IFMAR Section Chairman, the highest ranking IFMAR Official shall take the chair at any International Jury Meetings. The Race Director and Chairman are members of the International Jury but do not have a vote in the decisions. The Referees may be called by the Jury for opinions and explanations as deemed necessary. All decisions are by a simple majority vote. The Jury can request evidence and/or drivers presence pertaining to matters involved. Prior to the commencement of an International Jury Meeting, any mobile telephones in the meeting room must be turned off and placed on the meeting table until after the completion of the Meeting.
- 3.6.3 Jury members must be approved by their organizations.

#### **3.7 RESPONSIBILITY OF THE INTERNATIONAL JURY**

- 3.7.1 To decide in unforeseen situations.
- 3.7.2 To handle protests not covered by the Race Director's responsibility.
- 3.7.3 To change the race procedures or cancel the race whenever this is required due to safety aspects.
- 3.7.4 To see that the race is run according to the official IFMAR rules.
- 3.7.5 To make the decision on interrupting or cancelling a race due to rain or other weather conditions.
- 3.7.6 The Chairman of the International Jury will make official the results of the World Championship through the ranking IFMAR official available.
- 3.7.7 International Jury members may not have dual duties of being a race official (other than Race Director) or Referee. Jury members may be participants in the event but must allow an auxiliary representative to serve in any protests that concerns the jury member as a participant.

### 3.8 **INTERNATIONAL TEAM MANAGERS MEETING:**

The race director, at his discretion, is entitled to constitute an international team managers list and to have team manager meetings. The purpose is to facilitate general communication concerning eventual updates, specific race issues or proceedings. Team managers are responsible for ensuring swift dispatching of the relevant information to their drivers and by doing so cooperate to develop smooth race proceedings. Such meetings are informative only.

## **4 TECHNICAL RULES**

4.0 For the purpose of the IFMAR 1/10th scale Off-road World Championships, two (2) classes will be utilized with a separate Championship for each. The classes will be for two (2) wheel drive modified and four (4) wheel drive modified cars. The official measurements in these Technical Rules are the metric measurements.

### **4.1 TECHNICAL INSPECTION**

4.1.1 All cars must be presented for technical inspection at the start of the prior heat. No car will be allowed on the track surface without undergoing technical inspection first, including Lithium Voltage checks at random for some or all cars. Penalties for overcharging are indicated in the race procedures for batteries.

4.1.2 All cars must be presented for technical inspection at the end of each final.

4.1.3 All motors and batteries to be inspected as necessary during qualifying with mandatory inspection after the finals.

### **4.2 GENERAL SPECIFICATIONS**

4.2.1 Technical inspection will be prior to the start of racing and each heat/final. Cars may be inspected at any time during the racing program.

4.2.2 All cars in the World Championship finals will be impounded at the end of the finals for further technical inspection, such as motors, etc.

4.2.3 Only one (1) car per driver per class is allowed. All cars must be presented to Technical Inspection for an Initial Inspection before the start of Controlled Practice (see amended rule 1.5.6 relating to chassis marking for CP1 & CP2). This Initial Inspection is to determine that the car meets the IFMAR Technical Rules for this event.

When the car passes this Initial Inspection, the chassis of the car will be marked by the Technical Inspector. Marks which are made by engraving, and/or removal of chassis material, are to be avoided. A driver may refuse to have their chassis marked by methods which include removing chassis material.

Once the chassis is marked, the chassis may not be changed without the approval of the Race Director. The chassis may only be changed in the case of damage which cannot reasonably be repaired. Any replacement must be of the same: design, specifications and material as the original chassis registered.

Drivers must race the car he or she passed technical inspection with during qualifying and finals in accordance with the rules above.

4.2.4 Dimensional requirements (both classes);

Maximum overall length	18.00 inches	(457.2mm)
Maximum overall width	9.84 inches	(250.0mm), at any point of suspension travel.
Maximum height	8.00 inches	(203.2mm)

4.2.5 Bodies: All cars must use a 1:10th size body and have the appearance of full size off road racing cars. Pipe type bodies may be utilized on cars originally supplied in that configuration. A driver figure (minimum: head, shoulders, arms) must be firmly secured in proper position on cars using pipe type bodies. A driver figure is not required on enclosed body cars.

4.2.6 Side dams and spoilers: No add on side dams or spoilers allowed. Those moulded in body as on original car are allowed.

4.2.7 The body must be securely attached to car at all times while racing. If the body becomes loose and a track hazard or falls off during race, car must pull off the track until the body is re-attached.

4.2.8 Openings in the body shell shall be kept to a minimum. Openings for wing mounts, antennas, and battery on-off switch shall provide no more than 6,35mm in clearance. Specifically, electronic speedo's, servos, receivers, batteries, and servo savers are not allowed to protrude through original shell.

Body shell holes/vents: The front and rear ends of the shell must retain some of the original

profile of the two ends of the shell. Front and rear facing areas within the body shell surface which are 'marked' with the intention of removal to form "air scoops/ vents" are allowed to be removed, within a maximum dimension of 10mm in any direction regardless of the manufacturers marking.



If no "marked" air scoops/vents are designed in the original mould to assist airflow to the motor or ESC, then material may be removed to a maximum of 10 mm in any given direction within a maximum square area of size 30 mm x 30 mm, in two places only. Windows are not allowed to be removed or include holes, other than for the purpose of the antenna.

4.2.9 Wings: A maximum of two (2) wings may be used. One for the front and one for the rear.

Maximum size of wings:

Front 5 inches wide by 2.5 inch cord (127.00 mm x 63.5mm)

Rear 7 inches wide by 3.0 inch cord (177.80 mm x 76.2mm)

Max. wing side plate sizes: Height 50mm/1.97in. Length 80mm/3.15 in.

Vertical 'fins' included or attached within the wing area, must be no higher or lower than any side-plates. If no side plates are used, any vertical 'fins' within the wing area must not exceed 50mm maximum overall (top to bottom).

Front or Rear bi-level wings are not permitted.

4.2.10 Rollover antennas are not allowed. Antennas must be of a flexible non-metallic material.

4.2.11 Controlled tires and inserts must be used for controlled parts of the event in both classes. The type of tires, combinations and inserts for both classes is decided by the IFMAR Electric Executive together with the race organizer (race organizer recommends three types of tires and inserts for the 2wd rear axle and three combinations of front and rear tire together with their respective inserts for 4wd). On the 2wd front axle, tire and insert is not controlled. In 4wd different types maybe selected for the front and for the rear axle. The race organizer has to forward the recommendations to the IFMAR Electric Section Chairman eight (8) months before the events. The final decision will be made six (6) months before the events by a majority vote of the IFMAR Electric Executive.

The three (3) recommended types of tires and three (3) recommended types of inserts for both classes must be commercially available in the four (4) Blocs at the time of the organizer's recommendations, (eight (8) months prior to the events) and remain available up until the final decision six (6) months prior to the events. The selected controlled tire and controlled insert for both classes must continue to be commercially available in the four (4) Blocs from six (6) months prior to the event up until the commencement of the events.

The manufacturer/s who was/were selected to supply the tire/s and/or insert/s for the previous IFMAR 1/10th Off-Road World Championship events is/are not eligible to supply tire/s and/or insert/s for the next IFMAR 1/10th Off-road World Championship events.

All tires must be black. Foam tires are not allowed. Foam/cap tires are not allowed but internal foam inserts are permitted.

Tyre sizes:	Max width	44,45mm (1.75 inches)
	No minimum width.	
	Max tire diameter	90,00mm (3.544 inches)
Wheel sizes:	Min bead mounting diameter	41,28mm (1.625 inches)

Max bead mounting diameter 55,88mm (2.2 inches)  
 Bead mounting dimensions are measured at the point where the internal tire bead meets the wheel.  
 Max wheel diameter 61,47mm (2.42 inches)  
 Max wheel width 38,10mm (1.500 inches)

Wheel width is measured at the circumference of the wheel where the tyre is retained, the centre of the wheel maybe outside this dimension (see drawing below).

Wheel mounting. 12.00 mm. hexagon. Wheel centre hole. 5.00mm. dia.

The above dimensions are applicable for 2017 WC.

From 2019 onwards, a maximum standard 'wheel offset' will also be adopted for all Rear wheels and 4WD front wheels. (Front and rear will have different offset).

Starting 2019, maximum wheel off-sets will be :

Wheel off-set from mounting face. Rear: 11.00mm. max. 4WD Front: 4.00mm. max.

**MANUFACTURERS SHOULD BE AWARE THAT:** Cars must comply with maximum car width dimensions (250mm) when fitted with wheels using the above off-set dimensions.

Wheel off-set is measured from the hex. mounting face to the outside of the outer rim at the wheel circumference (see drawing).

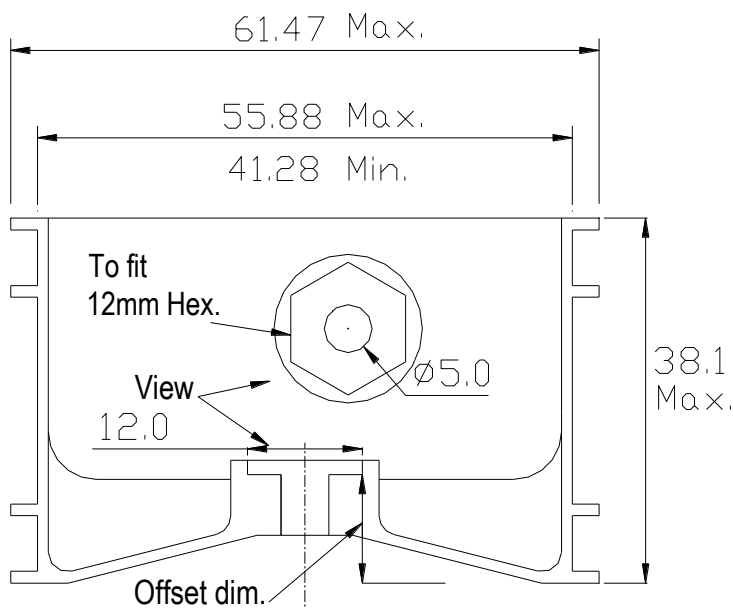

Internal locking ring may be used for the purpose of retaining the tire only. Ring cannot be used to increase the wheel's original size and/or the stiffness of the sidewall.

"Venting" holes in the internal rim of the wheel are allowed – maximum of two (2) holes, of maximum 6.0mm. diameter. "Cutting and Shutting" of tyres is not allowed. Modifications to tyre 'tread patterns' and 'location beads' are allowed by trimming or removal, but the addition of any material is prohibited excepting the glue used to retain the tyre to the wheel. Excess of glue that can be deemed to alter the performance of the tyre is not allowed. "Venting" holes are allowed to be cut in the tyres with no size/number restriction.

No tyre additives other than water are allowed, inside or outside of any tyre. Only organizer provided tyre cleaning spray/fluid can be used.

No 'tyre warmers' or similar devices are allowed to be used.

4.2.12 Radio equipment: All transmitters must be inspected and approved prior to use in the event. A maximum of two control devices may be used: i.e. two (2) servos or a servo and a speed control.

4.2.13 Reverse is not allowed - forward control only.

4.2.14 Only fixed single ratio transmissions allowed.

- 4.2.15 Controlled/Marked items: Each competitor can only use the car chassis assigned to him/her 'marked' by technical inspection (within the time-frame specified 1.5.6) detailing the competitor number.  
Other items will be checked and marked by Technical Inspection to assure they comply with technical rules/dimensions to reduce the time needed in Tech. prior to each Heat/Final – eg.(but not restricted to) motors, batteries, wings, wheels, tyres etc. These additional items are not restricted to the use of any specific competitor. Only the chassis is restricted to an individual competitor.

### **4.3 TWO WHEEL DRIVE CLASS**

- 4.3.0 Front wheel drive cars must run in 4wd class.
- 4.3.1 Two wheel drive cars: rear wheel drive cars only will be allowed.
- 4.3.2 Cars must conform to the general technical specifications.
- 4.3.3 Minimum weight limit:        3.25 Pounds    52 oz.                    1.474 Kilos

### **4.4 FOUR WHEEL DRIVE CLASS**

- 4.4.1 Only Four wheel drive and 2 wheel rear or front wheel drive cars will be allowed. Any car competing in the 4WD Class must have effective drive to the front wheels. Any car which is designated as 4WD, must be able to complete a lap of the track with either the front or rear pair of drive-shafts removed, and all settings of the remaining drive-train as it will be raced, in a reasonable time frame.
- 4.4.2 Cars must conform to the general technical specifications.
- 4.4.3 Minimum weight limit:        3.5 Pounds    56 oz.                    1.588 Kilos

### **4.5 DRIVER AIDS**

- 4.5.1 It is the objective of this rule to ensure that the IFMAR 1/10th Off-Road Electric World Championship be a test of driver skill. IFMAR seeks to limit the type of driver aids to a minimum to achieve this objective. Traction control, active suspension and steering control by gyroscopes are not allowed. Sensors fitted to the car for the purpose of measuring suspension movement, wheel speed or tire slip whilst the car is in motion are not allowed.
- 4.5.2 Unless an electronic or mechanical driver aid is listed below in rule 4.5.3 it is not allowed for use in IFMAR 1/10th Off-Road World Championships.
- 4.5.3 The fixed single ratio transmission may include a mechanical device/s between the drive motor output and the gearbox input for the purpose of controlling torque. (e.g. 'slipper' clutch/fluid clutch) This device/s must only be capable of setting or adjustment manually whilst the car is stationary.  
  
A differential may include a mechanism for apportioning torque over the axle/s (eg limited slip differential). This mechanism must only be capable of adjustment manually whilst the car is stationary  
  
Any type mechanical or electronic speed controller can be used.
- 4.5.4 Radio control receivers carried in the car may only have two devices (normally the steering servo and speed controller) connected, plus an optional separate battery supply for the powering of the radio control equipment/devices. The use of any further channels to receive electrical signals from sensors carried in the car is prohibited.  
  
It is not allowed to use any form of active telemetry.  
  
*Clarification:*  
*It is not allowed for any radio/wireless signals to be transmitted from the car to an external source during a race, that is judged to give the driver a competitive advantage during that particular race.*
- 4.5.5 Any competitor found in contravention of the spirit or fact of rule 4.5 will be disqualified from the World Championship meeting.

## **5 TRACK STANDARDS**

### **5.1 SURFACE**

The track surface can be dirt, or else partially or entirely covered with artificial turf. (Commonly referred to as Astro turf)

Other materials can be used in sections of the track such as table tops and jumps to assure the durability of those sections for the entire event.

Such other materials must be limited to less than 20% of the total track length.

Dirt sections should be of screened top soil / clay free from rocks and debris with only a minimum amount of sand and hard packed to provide a durable consistent racing surface for the duration of the event.

## 5.2 LAYOUT

A The track design should employ the following basic components:

- 1: Main straight should be between 25 to 30 meters
- 2: Track width should be a minimum of 3 meters at any part of the track
- 3: Jumps should be liberally used throughout the circuit and should include single, double and triple jump sections, all jumps must have a smooth transition.
- 4: Bumps, either a series of stutter bumps or moguls should be incorporated into the track design.
- 5: Additional features such as drop-offs, elevation changes, berms etc. may also be utilized to further enhance the design characteristics of the circuit.

B: In determining the physical location of the track layout it is recommended you consider the following:

1. Location of the drivers stand and rising/setting of the sun should be utmost importance. Additionally shadows cast upon the racing surface is also of great concern as not all the drivers may have to endure such conditions throughout a single round of qualifying.
2. Track location should also offer exceptional drainage should inclement weather be even a remote possibility.
3. Proximity to power, water and other such necessities is also essential to insure adequate maintenance, lighting (as necessary) and similar elements needed for a World Championship event.
4. The drivers stand should be located at least 10 feet back from the racing surface.

## 5.3 MAINTENANCE PROCEDURES

5.3.1 To ensure that a consistent and fair track is made available to all entrants regardless of heat number or round run, regular maintenance is absolutely essential. Perhaps the most important aspect of this maintenance is the use of a single crew that will be responsible for the track throughout the complete event. This should ensure consistent track conditions for practice, qualifying and main events.

5.3.2 Watering of the track surface should be done on a pre-determined schedule based on the needs of the track and the atmospheric conditions. Any schedule should be conceived in such a way that no one heat or only a few heats race on a just-watered track. This way any advantage/disadvantage will be shared by all entrants equally.

5.3.3 Track repairs should be made between heats as needed. This should prevent "extreme" deterioration of the racing surface throughout the event. Once again, if a schedule is set up for regular maintenance it should be staggered so that all drivers enjoy any advantage or disadvantage such maintenance may offer. Attention to jumps as well as turns and straight sections is equally important.

## 5.4 CONCLUSION

A track layout utilizing the suggested components and construction should very closely emulate a real off-road circuit that the full scale counterparts race on. Additionally track conditions should prove to be consistent and offer equal and fair opportunity for all competitors. The restriction of straight length, use of jumps, moguls etc. will also reduce the impact of exceptional batteries, motors etc. which once again yields an extremely fair and equitable yet competitive atmosphere.

### FINISH

JANUARY & DEC 2012, NOVEMBER 2014 (Kissimmee, USA) AUGUST 2016 (Beijing, China) OCTOBER 2016 (Las Vegas, USA) July 2018 (wheel offsets) - July 2019 (correction text controlled tyres)  
NOVEMBER 2019 (Fontana, USA)

